

# MRTA6 Dual Circuit [500kg]

The MRTA6 is the first lifter with 'Quadra-Tilt' - a unique geometric tilt mechanism that provides mechanical assistance to the operator.

This means that the force needed to tilt a load is less than half that typically required for a lifter that pivots around a single point. When a load is tilted to either the upright or the flat position, the lifter maintains the load automatically without using latches.

The dual circuit MRTA6 also features 360° continuous manual rotation as well as moveable pads and extensions arms that can accommodate a variety of load sizes and shapes.

## Key Features

- **Capacity: 500kg**
- **Dual circuit vacuum system with reserve tank, non-return valve and vacuum gauge for each circuit**
- **Mechanically assisted 90° tilt from vertical to horizontal**
- **Manual 360° rotation (continuous) lockable at eight intermediate positions**
- **Integral maintenance-free vacuum pump**
- **12v rechargeable battery with integral 110v or 240v charger and energy gauge**
- **Audio-visual low vacuum warning**
- **Four extension arms allow alternative configurations**
- **0° and 90° tilting locking latch system**
- **On-board control panel**

# Technical Data (mm)

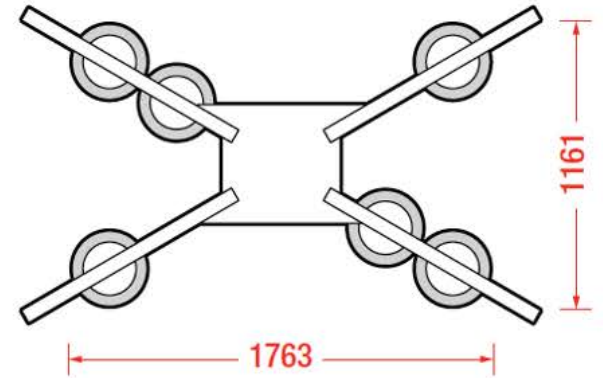
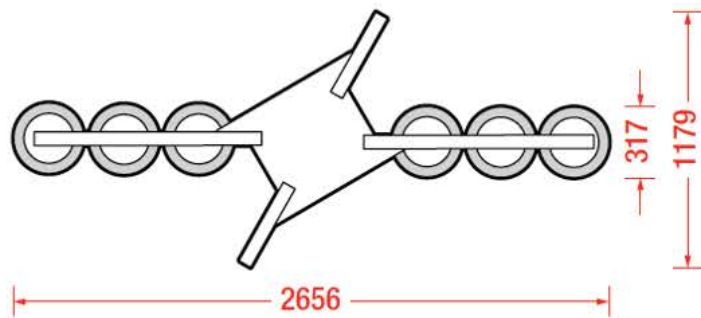
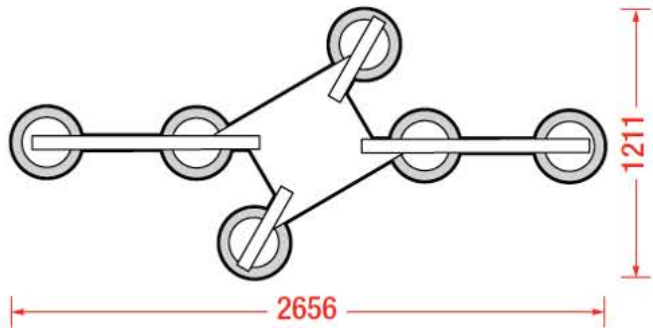
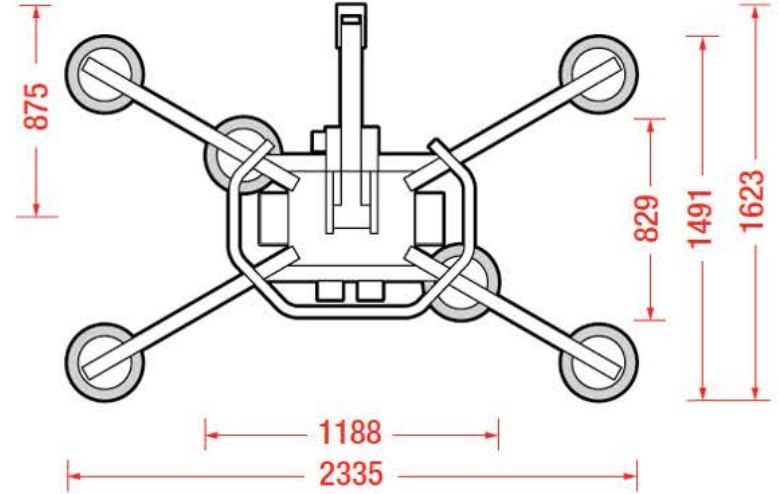
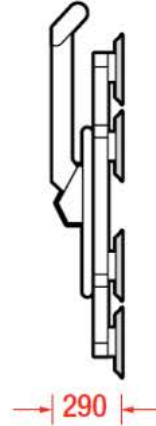
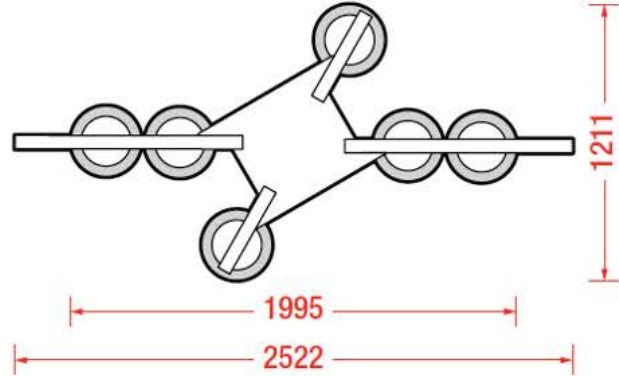
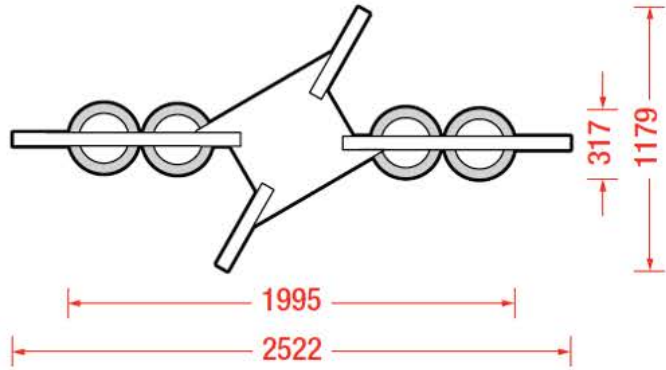
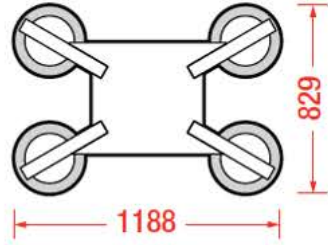
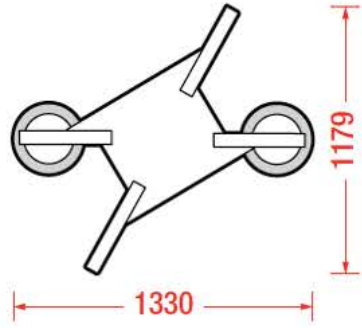

# Technical Specifications

<b>Safe working load</b> (smooth, clean surface at 60% vacuum)	capacity:	500kg	336kg	168kg
<b>Number of suction cups</b>	cups	6	4	2
<b>Suction cup</b>	description:	black rubber, not abrasion resistant, heat resistant up to 100°F		
<b>Suction cup diameter</b>	diameter:	305mm		
<b>Suitable for lifting</b>	material properties: surface: example:	gastight / non-porous smooth glass, plastic boards, ceramic plates, sheet metals, coated boards		
<b>Weight of lifter</b>	approx:	86kg	60kg	
<b>Depth of lifter</b>	depth:	290mm		
<b>Rotation</b>	rotation:	360° continuous lockable		
<b>Tilt</b>	tilt:	90° mechanically assisted & lockable		
<b>Vacuum system</b>	dual circuit:	1 pump, 2 vacuum reserve tanks		
<b>Voltage</b>	pump: battery charger:	12v DC from rechargeable battery 110v/240v 50/60Hz single phase factory selectable		
<b>Standard accessories</b>	standard:	4 x extension arms and 2 pads, 0° and 90° tilting locking latch system		
<b>Optional accessories</b>	optional:	radio remote control, Woods pad mount extensions, stone pads (405kg capacity), curved pads (405kg capacity), low marking pads, heat resistant pads		